

AC Forward Curve Single Inlet

FD180D/I Series Centrifugal Fan

180mm (7.0in)



GENERAL SPECIFICATIONS

- Impeller:** Galvanized Steel
- Life:** 40,000 hours
- IP Rating:** IP44
- Operating Temp:** -25°C~+40°C
- Bearings:** Ball

FEATURES

- High efficiency inlet design
- Lubricated maintenance-free ball bearings
- Vibration-free operation
- Precision balanced for superior performance
- Compact and rugged construction

model	voltage (V)	freq (Hz)	current (A)	power (W)	speed (RPM)	airflow (m ³ /h)	airflow (CFM)	pressure (Pa)	capacitor μF	insulation class
FD180D	230	50/60	0.60/0.83	135/190	1310/1370	730/770	430/453	185/270	4/450	F
FD180I	115	60	1.6	185	1400	760	447	258	16/450	F

Performance Curves

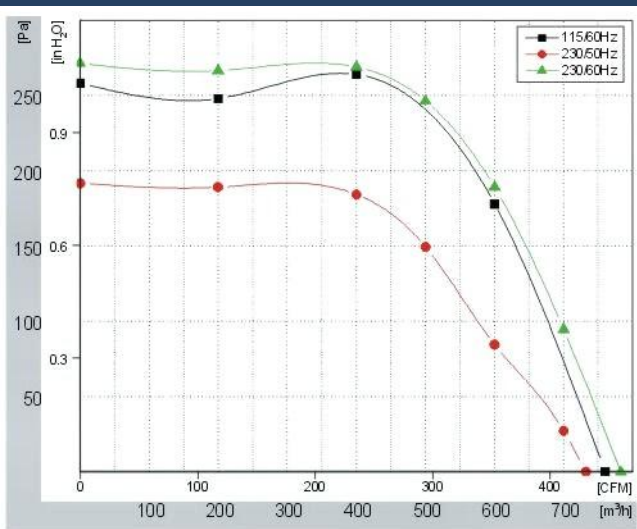

Dimensions (mm)

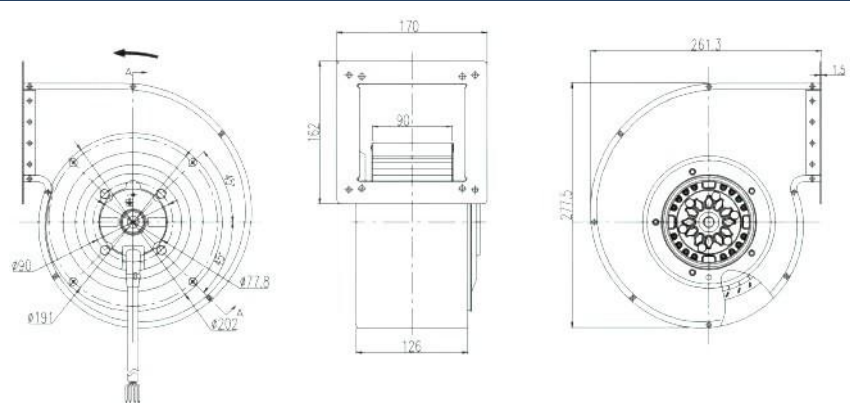

Applications

HVAC, cabinet cooling, medical equipment, military applications, air filtration, semiconductors, commercial and industrial cooling.



T 1.888.546.0524 • F 1.610.647.0319
 email: sales@pelonistech.com • www.pelonistechnologies.com

