



9232-7

92 x 92 x 32mm (3.62 x 3.62 x 1.26in)

DC Fans

www.pelonistechnologies.com

HIGH PERFORMANCE • HIGH EFFICIENCY

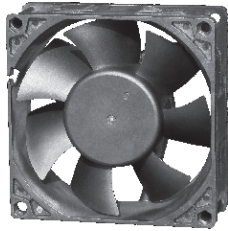

FRAME: Thermoplastic, PBT (30%), UL94-V0
IMPELLER: Thermoplastic PBT (GF 15%), UL94-V0
BEARING SYSTEM: Ball Bearing or Sleeve Bearing
OPERATING LIFE: Ball: 50,000 hrs; Sleeve: 30,000 hrs
OPERATING TEMP: -10°C to +70°C @35-85% RH

LEAD WIRE: UL 1007, AWG 24/260mm, Red(+), Black(-)
PROTECTION: Locked rotor protected for minimum 72 hours



- RoHS
- UL
- cUL
- CE

Available Features															
1a IR	1b AS	1c MS	2a FG	2b RD	2c Rdb	2d LD	3 SG/PWM	4 OV	5a TPWM	5b RPWM	6 CL	7 CS	8a VPWM	8b IPWM	8c PPWM
●	●		●	●	●	●		●			●	●			

To add a desired feature to a fan, replace the Part Number suffix "x" with the available feature listed. (e.g. to add feature "2a" to fan Part Number G9232H12BPLBx-7, change the Part Number to G9232H12BPLB2a-7).

Part Number	Voltage (VDC)	Current (A)	Power (Watts)	Speed (RPM)	Air Flow (Q)		Pressure (P)		Noise (dBA)	Unit Weight (QTY/CTN)
					(CFM)	(m³/min)	(mmAq)	(in H ₂ O)		
G9232Y12BPLBx-7	12 (07~14)	0.638	7.65	4200	86.06	2.437	11.63	0.458	44.89	175g (100pcs)
G9232X12BPLBx-7		0.576	6.91	3750	77.04	2.182	9.30	0.366	41.94	
G9232H12BPLBx-7		0.378	4.54	3250	66.53	1.884	7.15	0.281	38.23	
G9232M12BPLBx-7		0.269	3.23	2900	58.64	1.661	5.68	0.224	35.30	
G9232L12BPLBx-7		0.183	2.20	2500	50.48	1.429	3.98	0.157	31.52	
G9232Y24BPLBx-7	24 (15~27)	0.322	7.73	4200	86.06	2.437	11.63	0.458	44.89	175g (100pcs)
G9232X24BPLBx-7		0.220	5.28	3750	77.04	2.182	9.30	0.366	41.94	
G9232H24BPLBx-7		0.160	3.84	3250	66.53	1.884	7.15	0.281	38.23	
G9232M24BPLBx-7		0.120	2.88	2900	58.64	1.661	5.68	0.224	35.30	
G9232L24BPLBx-7		0.076	1.82	2500	50.48	1.429	3.98	0.157	31.52	
G9232Y48BPLBx-7	48 (30~57)	0.161	7.70	4200	86.06	2.437	11.63	0.458	44.89	175g (100pcs)
G9232X48BPLBx-7		0.110	5.28	3750	77.04	2.182	9.30	0.366	41.94	
G9232H48BPLBx-7		0.080	3.84	3250	66.53	1.884	7.15	0.281	38.23	
G9232M48BPLBx-7		0.060	2.88	2900	58.64	1.661	5.68	0.224	35.30	
G9232L48BPLBx-7		0.038	1.82	2500	50.48	1.429	3.98	0.157	31.52	

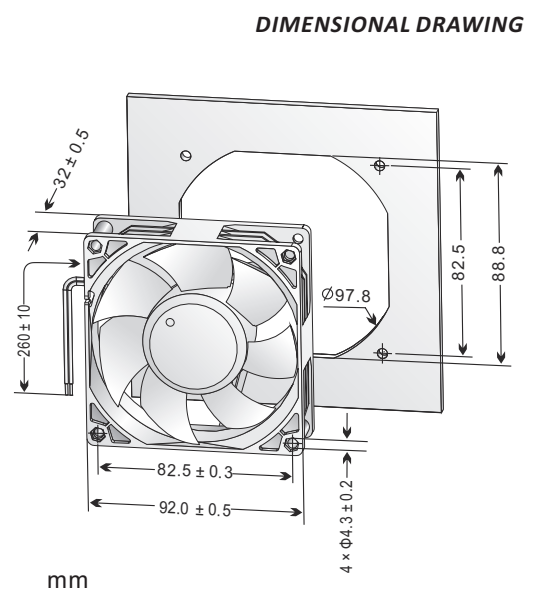
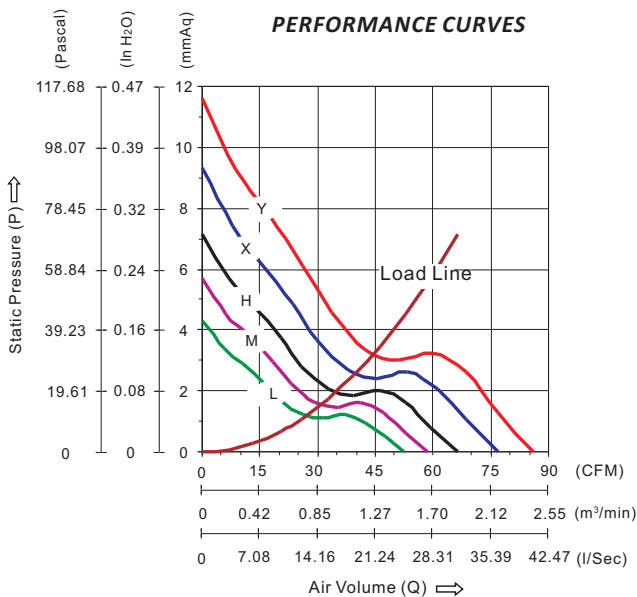

- All fans listed refer to double ball bearing fans; sleeve bearing fans may consume about 10% more power for the same speed.
- Noise measurements are taken with a background noise of 16.8 dBA.
- Please see "Available Features Index" for a summary explanation of each feature
- Specifications are subject to change without notice.



sales@pelonistech.com • T888.546.0524 • F610.647.0319