



1751-7

172 x 150 x 51mm (6.77 x 5.91 x 2.01in)

DC Fans

www.pelonistechnologies.com

HIGH PERFORMANCE • HIGH EFFICIENCY

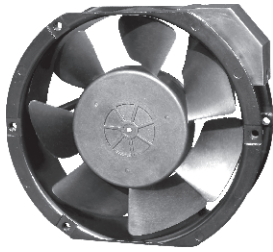

- RoHS
- UL
- cUL
- CE

FRAME: Thermoplastic, PBT (30%), UL94-V0
IMPELLER: Thermoplastic PBT (GF 15%), UL94-V0
BEARING SYSTEM: Ball Bearing or Sleeve Bearing
OPERATING LIFE: Ball: 50,000 hrs; Sleeve: 30,000 hrs
OPERATING TEMP: -10°C to +70°C @35-85% RH

LEAD WIRE: UL 1007, AWG 24/210mm, Red(+), Black(-)
PROTECTION: Locked rotor protected for minimum 72 hours



Available Features

1a	1b	1c	2a	2b	2c	2d	3	4	5a	5b	6	7	8a	8b	8c
IR	AS	MS	FG	RD	Rdb	LD	SG/PWM	OV	TPWM	RPWM	CL	CS	VPWM	IPWM	PPWM
●	●		●	●	●	●		●			●	●			

To add a desired feature to a fan, replace the Part Number suffix "x" with the available feature listed. (e.g. to add feature "2a" to fan Part Number G1751H12BALBx-7, change the Part Number to G1751H12BALB2a-7).

Part Number	Voltage (VDC)	Current (A)	Power (Watts)	Speed (RPM)	Air Flow (Q)		Pressure (P)		Noise (dBA)	Unit Weight (QTY/CTN)
					(CFM)	(m³/min)	(mmAq)	(in H ₂ O)		
G1751H12BALBx-7	12 (07~14)	1.643	19.71	2900	251.64	7.126	13.99	0.551	54.75	748g (24pcs)
G1751M12BALBx-7		0.910	10.92	2500	219.10	6.204	10.30	0.405	51.34	
G1751L12BALBx-7		0.583	6.99	2100	185.86	5.263	6.97	0.275	46.81	
G1751Y24BALBx-7	24 (15~27)	1.375	32.99	3500	313.15	8.867	18.74	0.738	59.65	748g (24pcs)
G1751X24BALBx-7		1.027	24.65	3200	282.96	8.013	15.70	0.618	57.53	
G1751H24BALBx-7		0.720	17.28	2900	251.64	7.126	13.99	0.551	54.75	
G1751M24BALBx-7		0.475	11.40	2500	219.10	6.204	10.30	0.405	51.34	
G1751L24BALBx-7		0.288	6.91	2100	185.86	5.263	6.97	0.275	46.81	
G1751Y48BALBx-7	48 (30~57)	0.650	31.18	3500	313.15	8.867	18.74	0.738	59.65	748g (24pcs)
G1751X48BALBx-7		0.519	24.90	3200	282.96	8.013	15.70	0.618	57.53	
G1751H48BALBx-7		0.358	17.20	2900	251.64	7.126	13.99	0.551	54.75	
G1751M48BALBx-7		0.233	11.17	2500	219.10	6.204	10.30	0.405	51.34	
G1751L48BALBx-7		0.142	6.81	2100	185.86	5.263	6.97	0.275	46.81	

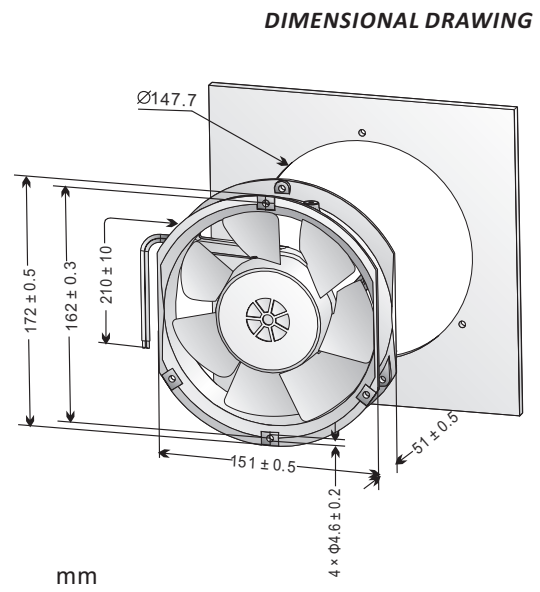
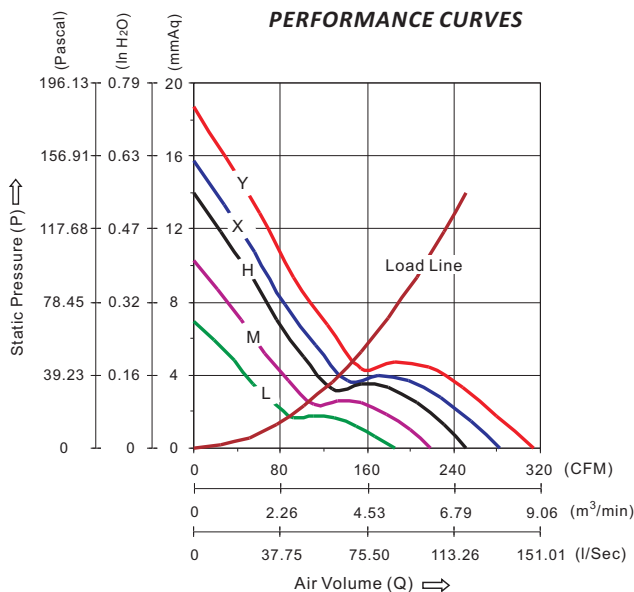

- All fans listed refer to double ball bearing fans; sleeve bearing fans may consume about 10% more power for the same speed.
- Noise measurements are taken with a background noise of 16.8 dBA.
- Please see "Available Features Index" for a summary explanation of each feature
- Specifications are subject to change without notice.



sales@pelonistech.com • T888.546.0524 • F610.647.0319